

ELENCO PEZZI DI RICAMBIO - LISTE PIECES DETACHEES SPARE PARTS LIST - ERSATZTEILLISTE PIEZAS DE REPUESTO

Esploso macchina, Dessin appareil, Machine drawing, Explosions Zeichnung des Geräts, Diseño seccionado maquina.

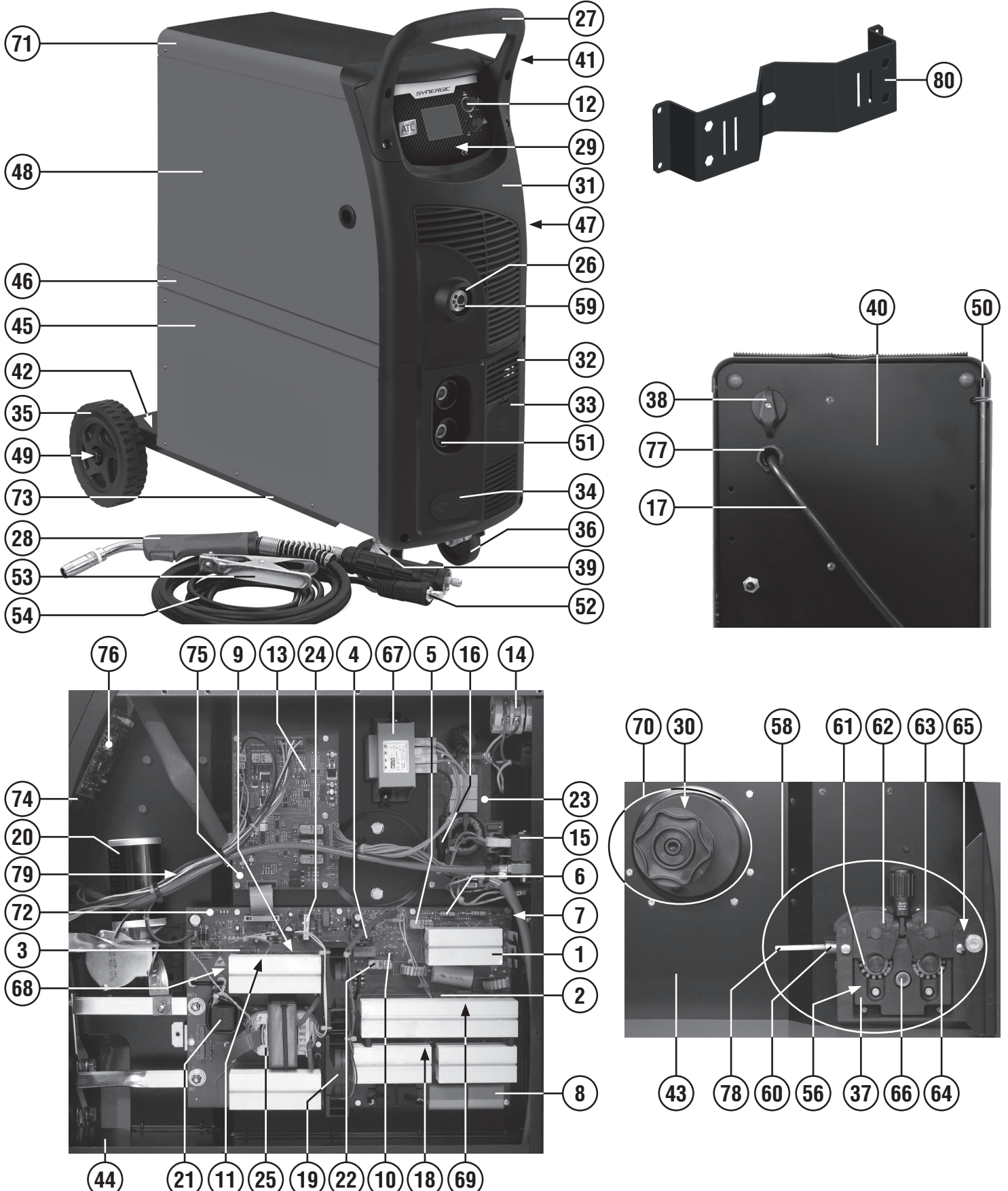

Per richiedere i pezzi di ricambio senza codice precisare: codice del modello; il numero di matricola; numero di riferimento del particolare sull'elenco ricambi.

Pour avoir les pieces detachees, dont manque la reference, il faudra preciser: modele, logo et tension de l'appareil; denomination de la piece; numero de matricule.

When requesting spare parts without any reference, pls specify: model-brand and voltage of machine; list reference number of the item; registration number.

Wenn Sie einen Ersatzteil, der ohne Artikel Nummer ist, benoetigen, bestimmen Sie bitte Folgendes: Modell-zeichen und Spannung des Geraetes; Teilliste Nuemmer; Registriernummer.

Por pedir una pieza de repuesto sin referencia precisar: modelo-marca e tension de la maquina; numero de referencia de lista; numero de matricula.

Per individuare lo schema elettrico corrispondente alla vostra macchina, rifarsi all'ultima cifra "X" del numero di matricola (N. 0000/X) riportato sul frontale.
 Pour reperer le schéma électrique correspondant à votre appareil, vérifier le dernier chiffre "X" du numéro de série (N. 0000/X) reporté sur la partie frontale.

In order to find the electrical diagram corresponding to your model, check the last number "X" of the serial number (N. 0000/X) printed on front panel.

Um den schaltplan, der ihrem gerät entspricht, ausmachen zu können, müssen sie die letzte ziffer "X" der matrikelnummer (N. 0000/X), die auf der frontseite angebracht ist, beachten.
 Para la identificación del esquema eléctrico, correspondientes, a su máquina, referase a la última cifra "X" del número de placa (N. 0000/X) instalado sobre el frontal.

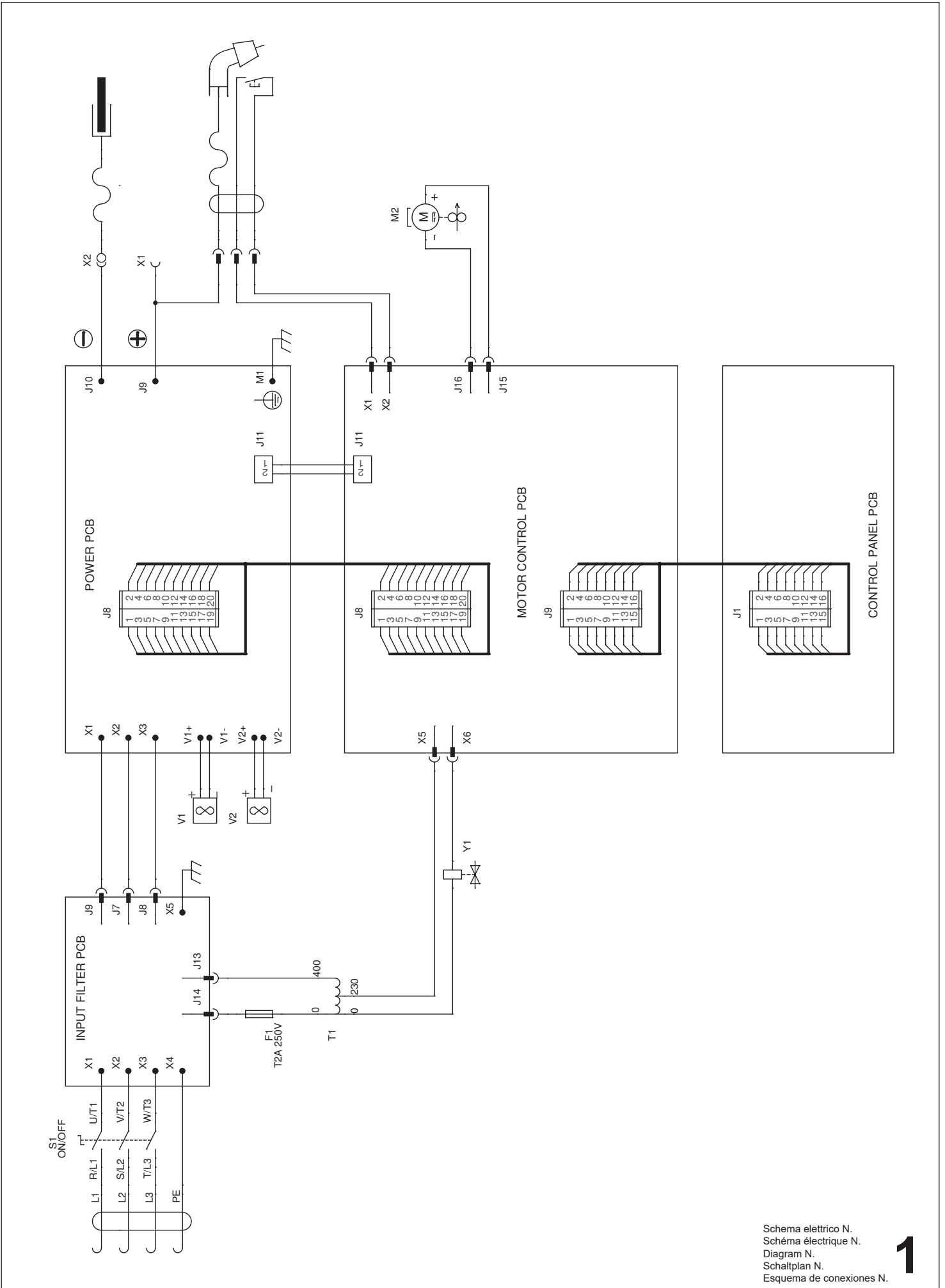

Schema elettrico N.
 Schéma électrique N.
 Diagram N.
 Schaltplan N.
 Esquema de conexiones N.

REF.	ELENCO PEZZI DI RICAMBIO PIECES DETACHEES SPARE PARTS LIST ERSATZTEILLISTE PIEZAS DE REPUESTO
1	Ponte monofase Pont monophasé Single phase bridge Einfasige brücke Puente monofásico
2	Res. Met. Res. Met. Res. Met. Res. Met. Res. Met.
3	Res. Met. Res. Met. Res. Met. Res. Met. Res. Met.
4	Igbt Igbt Igbt Igbt Igbt
5	Relé Relais Relais Relais Relais
6	Resistenza Resistance Resistance Widerstand Resistencia
7	Varistore Varistor Varistor Varistor Varistor
8	Condensatore Condensateur Condenser Kondensator Condensator
9	Diode Diode Diode Diode Diode
10	Res. Met. fuse Res. Met. fuse Res. Met. fuse Res. Met. fuse Res. Met. fuse
11	Termostato Thermostat Thermal switch Thermostat Termostato
12	Manopola encoder Poignee encoder Encoder knob Griff encoder Manija encoder
13	Fusibile Fusible Fuse Sicherung Fusible
14	Commutatore Commutateur Switch Schalter Switch
15	Elettrovalvola Electrovanne Electrovalve Elektroventil Electrovalvula
16	Fusibile Fusible Fuse Sicherung Fusible
17	Cavo alim. Cable alim. Mains cable Netzkabel Cable alim.
18	Trasformatore di corrente Transformateur de courant Current transformer Stromwandler Transformador de corriente
19	Ventilatore Ventilateur Fan Ventilator Ventilador
20	Motore Moteur Motor Motor Motor
21	Induttanza Inductance Inductance Drossel Induccion

REF.	ELENCO PEZZI DI RICAMBIO PIECES DETACHEES SPARE PARTS LIST ERSATZTEILLISTE PIEZAS DE REPUESTO
22	Induttanza Inductance Inductance Drossel Induccion
23	Kit scheda filtro Kit platine filtre Filter card kit Filterkartekit Kit tarjeta filtro
24	Trasformatore flyback ausiliario Transformateur flyback auxiliaire Flyback auxiliary transformer Flyback hilfstransformator Transformador flyback auxiliar
25	Trasformatore potenza Transformateur de puissance Power trafo Leistungstransformer Transformador de potencia
26	Protezione attacco torcia Support isolant torche Torch connection protection Brennersisolierlager Sosten isolator antorcha
27	Assieme manico Set poignee Handle set Handgriff set Set manija
28	Torcia mig Torche mig Mig torch Mig brenner Antorcha mig
29	Kit supporto display Kit support display Display holder kit Display halterung kit Kit soporte display
30	Distanziale per aspo Entretoise pour support bobine Reel spacer Distanzstueck Espaciador por aspa
31	Frontale superiore Partie frontal superieur Upper front panel Obere geraetefront Frontal superior
32	Frontale inferiore Partie frontal inferieur Lower front panel Geraetefront unten Frontal inferior
33	Tappo Bouchon Cap Stopfen Tapon
34	Tappo Bouchon Cap Stopfen Tapon
35	Ruota Roue Wheel Rad Rueda
36	Ruota Roue Wheel Rad Rueda
37	Protezione Protecion Cover Deckel Proteccion
38	Assieme manopola per commutatore Set poigne pour commutateur Switch knob set Umschaltergriff set Set manija para conmutador
39	Supporto girevole + freno Support tournant + frein Swivel support + brake Drehbarerhalter + bremse Sosten giratorio + freno
40	Retro Partie arriere Back panel Rueckseite Trasera
41	Gancio appenditorcia Crochet support torche Torch hook Brennershaken Gancho antorcha
42	Staffa asse ruote Bride axe roues Wheels axle bracket Radachsebuegel Estribo eje ruedas

REF.	ELENCO PEZZI DI RICAMBIO PIECES DETACHEES SPARE PARTS LIST ERSATZTEILLISTE PIEZAS DE REPUESTO
43	Diaphragma Diaphragme Diaphragm Diaphragma Diafragma
44	Ripiano Surface Surface Deckel Plano
45	Fianco dx Partie lateral Right side panel Rechtes seitenteil Panel derecho
46	Vano aspo Support bobine vain Reel space Wickler raum Espacio aspa
47	Fianco sx Partie lateral Side panel Linkes seitenteil Panel izquierdo
48	Sportello Guichet Door Tuer Portezuela
49	Asse ruote Axe roues Wheels axle Radachse Eje ruedas
50	Perno sportello Pivot guichet Door pin Tuerzapfen Perno portezuela
51	Presa atlas Prise atlas Atlas socket Atlas steckdose Enchufe atlas
52	Spina atlas Fiche atlas Atlas plug Atlas stecker Enchufe atlas
53	Pinza di massa Borne de masse Work clamp Masseklemme Borne de masa
54	Cavo + pinza massa + atlas Cable + pince masse + atlas Cable + work clamp + atlas Kabel + massezange + atlas Cable + pinca masa + atlas
55	Rullino traino 4r ø 0.6fe-0.8/0.9fe "p-k" Galet 4r ø 0.6fe-0.8/0.9fe "p-k" Feed roll 4r ø 0.6fe-0.8/0.9fe "p-k" Vorschubrolle 4r ø 0.6fe-0.8/0.9fe "p-k" Roldana 4r ø 0.6fe-0.8/0.9fe "p-k"
56	Rullino traino 4r ø 0.8fe-1.0fe "p-k" Galet 4r ø 0.8fe-1.0fe "p-k" Feed roll 4r ø 0.8fe-1.0fe "p-k" Vorschubrolle 4r ø 0.8fe-1.0fe "p-k" Roldana 4r ø 0.8fe-1.0fe "p-k"
57	Rullino traino 4r ø 1.2fe-1.6fe "p-k" Galet 4r ø 1.2fe-1.6fe "p-k" Feed roll 4r ø 1.2fe-1.6fe "p-k" Vorschubrolle 4r ø 1.2fe-1.6fe "p-k" Roldana 4r ø 1.2fe-1.6fe "p-k"
58	Traino 4 rulli Devidoir 4 rouleaux 4 Roll wirefeeder 4 Räder drahtvorschub Alimentador de hilo 4 rodillos
59	Attacco torcia Attelage torche Torch connection Brenneranschluss Enganche soplete
60	Entrata guida filo Entree guide fil Wire guide inlet Drahtfuehrungsseeleingang Entrata vaina guidaera alambre
61	Adattatore Adaptateur Adapter Zahnrad Adaptador
62	Ancora controrullino sinistra Ancre contre-galet gauche Left anchor for pressure roller Linker anker für gegenrolle Ancora izquierda para contra roldana
63	Ancora controrullino destra Ancre contre-galet droit Right anchor for pressure roller Rechter anker für gegenrolle Ancora derecha para contra roldana

REF.	ELENCO PEZZI DI RICAMBIO PIECES DETACHEES SPARE PARTS LIST ERSATZTEILLISTE PIEZAS DE REPUESTO
64	Ingranaggio motore Engrenage motor Motor drive gear Motorszahnrad Engranaje motor
65	Tubo capillare Tuyau capillaire Wire conduit Kapillarrohr Tubo capilar
66	Ingranaggio Engrenages Gears Zahnrad Engranaje
67	Kit autotrasfo Kit autotrasfo Autotrasfo kit Autotrasfo kit Kit autotrasfo
68	Kit diodi Kit diodes Diode kit Diode kit Kit diodo
69	Kit igbt + trasformatore impuls Kit igbt + transformateur d'impulsions Kit igbt + impulse transformer Kit igbt + impuls-transformator Kit igbt + transformador de impulsos
70	Kit aspo Kit support bobine Reel kit Wickler kit Kit aspa
71	Kit mantello Kit capot Cover kit Deckelkit Kit panel de cobertura
72	Kit scheda completa Kit fiche complete Complete pcb kit Komplette karte kit Kit tarjeta completa
73	Kit fondo Kit chassis Bottom kit Bodenteil kit Kit fondo
74	Kit frontale Kit partie frontal Front panel kit Geraetefront kit Kit frontal
75	Kit scheda controllo Kit carte controle Control board kit Steuerungskarte kit Kit tarjeta control
76	Kit scheda pannello Kit platine frontal Kit front panel card Kit geraetefrontskarte Kit tarjeta frontal
77	Kit pressacavo + ghiera Kit presse cable + embout Kit cable bushing + ring nut Kit kabelhalter + nutmutter Kit prensa cable + virola
78	Kit guaina entrata motore Kit gaine entree moteur Gas hose kit Drahtfuehrungsseelekit Kit vaina guidaera alambre
79	Fusibile Fusible Fuse Sicherung Fusible
80	Staffa portabombola Etrier porte-bouteille Bottle-holder bracket Kasten fuer flasche Estribo porta bombona

